



Series 80-SC Split-Coupled Vertical In-Line Centrifugal Pump

BX-115C

 **Bell & Gossett**
a xylem brand

B&G Series 80-SC Split-Coupled Vertical In-Line Centrifugal Pump

Applications

- Hydronic Heating and Cooling Systems
- Industrial Process
- General Service
- Pressure Boosting

Advantages

- Low Supply and Return Arrangement
- Space Saving Design
- Easy Maintenance
- Support Ring for Easy Installations

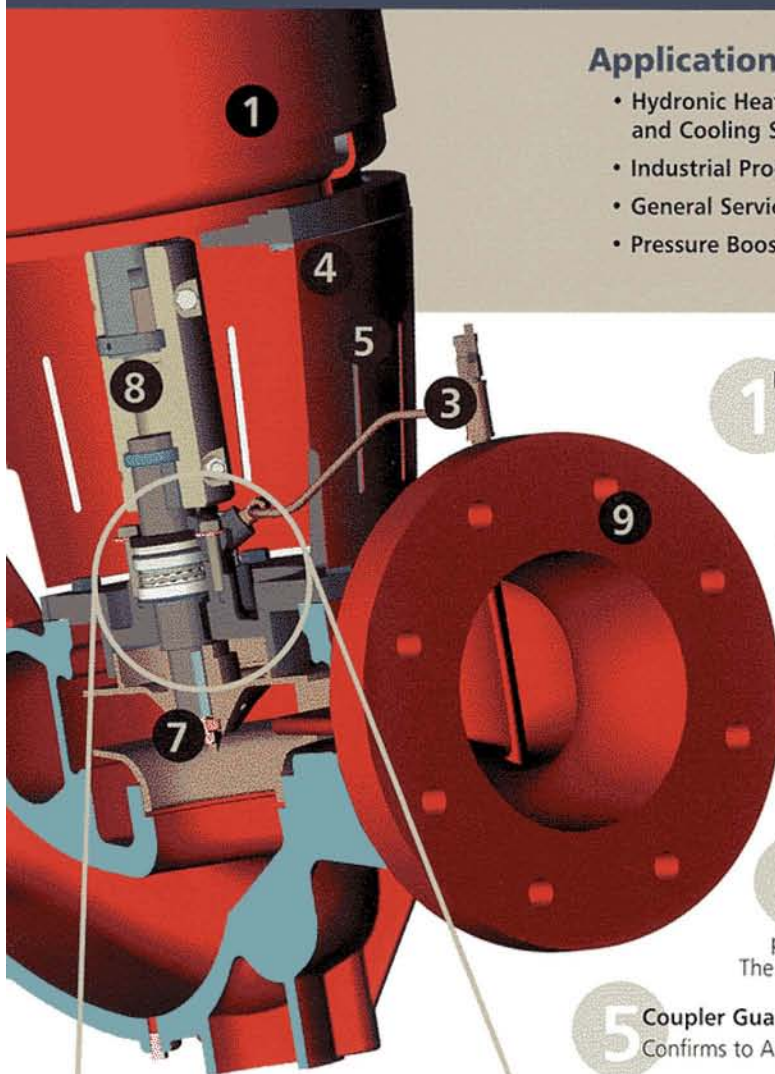

1 Motor

The Series 80-SC is to be fitted with 50 Hertz IEC motors that meet International Standards IEC 6034. In addition, the Series 80-SC will accept 50 and 60 Hertz TC-face NEMA motors.

2 Mechanical Seal

The seal has a compact *Rotating Unitized Seal Head* design for easier seal replacement. The positive metal-to-metal drive system reduces the torsional stress on the bellows. The bellows are pressure supported without creases or folds, creating lower stress, and resulting in longer seal life.

3 External Flush

The external flush line has a manual valve to remove air from the seal chamber to ensure cooling liquid at the seal for fast initial start-up.

4 Motor Bracket

Brackets are designed for a wider access area for easier seal removal. The combination motor bracket/volute coverplate assures positive concentric alignment of the motor to the pump casing. The motor bracket will accept 50 Hertz IEC and 50/60 Hertz TC motors.

5 Coupler Guard

Confirms to ANSI and OSHA for safe operation.

Ease of Serviceability

The axially-split spacer coupling permits seal maintenance without disturbing the pump or motor. The seal can be removed between the gap in the pump and motor shaft when the coupler is removed.

7 Impeller

The 80-SC impeller is balanced to ANSI grade 6.3 and provides years of trouble free service.

8 Pump Shaft

The 416 stainless steel pump shaft provides high levels of corrosion resistance to the pumped fluid.

9 Volute

An Anti-Swirl vane below the impeller eye keeps NPSHR to a minimum. The 6" and 8" pumps include a splitter volute to minimize radial loads for extended bearing and mechanical seal life. The volute includes a support ring on the bottom of the casing for installations adjacent to the floor.

10 Throttle Bushing

Antimony-impregnated carbon graphite throttle bushing for longer service life.

Standard
Inside Seal

Construction Materials (For parts in contact with fluid pumped)

| Description | Bronze Fitted Pump | All Iron Pump |
|-----------------------------------|-------------------------|-------------------------|
| Shaft | 416SS Stainless Steel | 416SS Stainless Steel |
| Volute | Cast Iron ASTM #A159 | Cast Iron ASTM #A159 |
| Impeller | Cast Bronze ASTM #B584 | Cast Iron ASTM #A159 |
| Impeller Key | Stainless Steel | Stainless Steel |
| Impeller Lock Washer | Stainless Steel | Stainless Steel |
| Impeller Capscrew | Stainless Steel | Stainless Steel |
| Volute Gasket | Cellulose Fiber | Cellulose Fiber |
| Throttle Bushing | Carbon Graphite | Carbon Graphite |
| Seal Assemblies | | |
| • Standard Seal – Inside Flushed | | |
| Bellows | EPR | EPR |
| Faces | Carbon-Ceramic | Carbon-Ceramic |
| Metal Parts | 316 Stainless Steel | 316 Stainless Steel |
| Spring | 316 Stainless Steel | 316 Stainless Steel |
| • Optional Seal – Inside Flushed | | |
| Bellows | EPR | EPR |
| Faces | Carbon-Tungsten Carbide | Carbon-Tungsten Carbide |
| • Optional Seal – Outside Flushed | | |
| O-Rings | EPR | EPR |
| Faces | Carbon-Ceramic | Carbon-Ceramic |
| Metal Parts | Stainless Steel | Stainless Steel |

Standard pump construction is 175 psi working pressure with 125 ANSI flange drilling.
Optional 250 psi working pressure with 250 ANSI flange drilling is available.

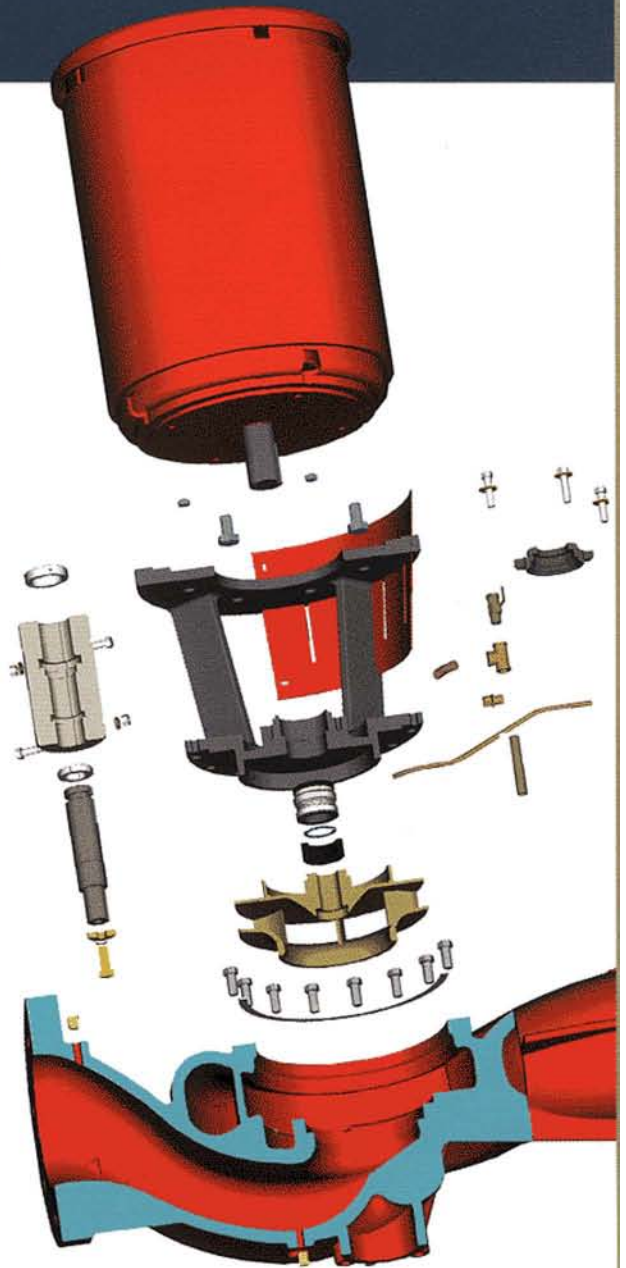

Seal Selection Guide

A. Standard Seal – Inside with flush line.

EPR/Carbon-Ceramic pH limitations 7-9; Temperature Range -20° to +250° F (-29° to +121° C).* Maximum pressure is 175 psi (12 bar).

B. Optional Seal – Inside with flush line.

EPR/Carbon-Tungsten Carbide pH limitations 7-11; Temperature Range -20° to +250° F (-29° to +121° C).* For use on open or closed clear water systems. Maximum pressure is 250 psi (17 bar).

C. Optional Seal – Outside with flush line.

EPR/Carbon-Ceramic Type "8B2"; pH limitations 7-9; Temperature Range -20° to +250° F (-29° to +121° C).* For use on closed or open systems where the pressure requirements exceed the limitations of the standard seal or an alternate seal design is desired. Maximum pressure is 250 psi (17 bar).

* For operating conditions above 250° F (121° C) and no greater than 300° F (149° C) a cooled flush is required. On closed systems cooling is accomplished by inserting the optional heat exchanger kit in the flush line to cool the seal flushing fluid.

Flush line filters and sediment separators are available on request.

Optional Outside Seal



Selection Charts

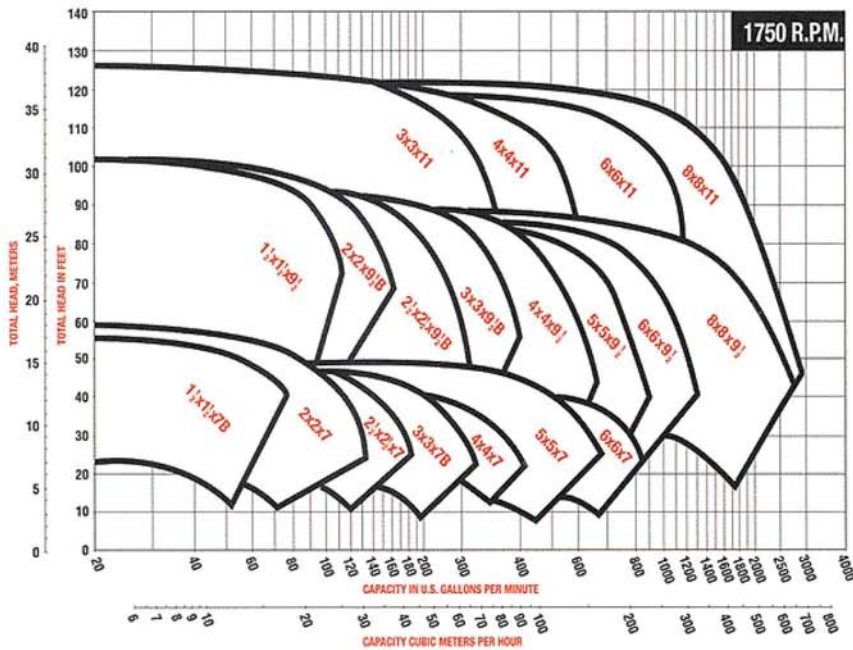
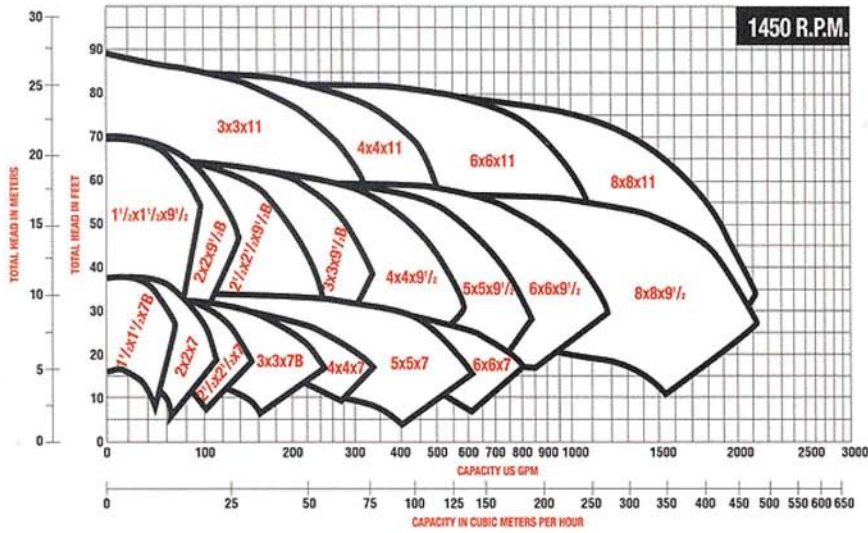

Engineering Specifications

Furnish and install pumps with capacities as shown on plans. Pumps shall be split-coupled in-line, single-stage design, for installation in a vertical position motor up, capable of being serviced without disturbing piping connections.

Pump volute shall be of Class 30 cast iron. It shall be designed with a base ring matching an ANSI 125# flange for pump support. The impeller shall be of cast bronze, enclosed type, balanced to Hydraulic Institute Standards (ANSI/HI 9.6.4.5-2000, figure 9.6.4.15B). The allowable residual imbalance conforms to ANSI grade 6.3, keyed to the stainless steel shaft and secured by a locking capscrew. The pump shaft shall be guided by a carbon graphite lower throttle bushing.

The combination motor bracket and volute coverplate shall be a one-piece unit to ensure concentric alignment of the motor to the pump casing.

The liquid cavity shall have a tapped flush line with manual valve to remove air from the seal chamber for fast initial start-up. The mechanical seal shall have a compact *Rotating Unitized Seal Head* design with EPR elastomer bellows and a positive metal-to-metal drive system to reduce the torsional stress on the bellows. The bellows will be pressure supported without creases or folds for long life.

The spacer coupling shall be of high tensile aluminum, split to allow the servicing of the seal without disturbing the pump or motor. The motor bracket shall contain a carbon steel coupler guard conforming to both ANSI B15.1 section 8 and OSHA 1910.219 standards for safety.

(Optional) The seal flush line shall be fitted with a factory installed 50 micron cartridge filter (cyclone separator when pump differential pressure exceeds 30 psig) and sight flow indicator.

Pumps shall be rated for continuous operation at a minimum of 175 psi (12 bar) working pressure (optional 250 psi [17 bar]) and 250° F (121° C). The volute shall have gauge tappings at the suction, and discharge nozzles and vent and drain tappings at the top and bottom.

Motor shall be energy efficient complying to IEC or NEMA specifications and shall be the size, voltage and enclosure called for on the plans. It shall have heavy-duty grease-lubricated ball bearings, completely adequate for the maximum load for which the pump is designed.

Each pump shall be factory tested per Hydraulic Institute standards. It shall then be thoroughly cleaned and painted with at least one coat of high-grade machinery enamel prior to shipment.

Pumps shall be Series 80-SC as manufactured by Bell & Gossett.

xylem
Let's Solve Water

Xylem Inc.
8200 N. Austin Avenue
Morton Grove, Illinois 60053
Phone: (847) 966-3700
Fax: (847) 965-8379
www.xylem.com/brands/bellgossett

Bell & Gossett is a trademark of Xylem Inc. or one of its subsidiaries.
© 2012 Xylem Inc. BX-115C May 2003